

# Pumpsaver® Braided Pump Connectors

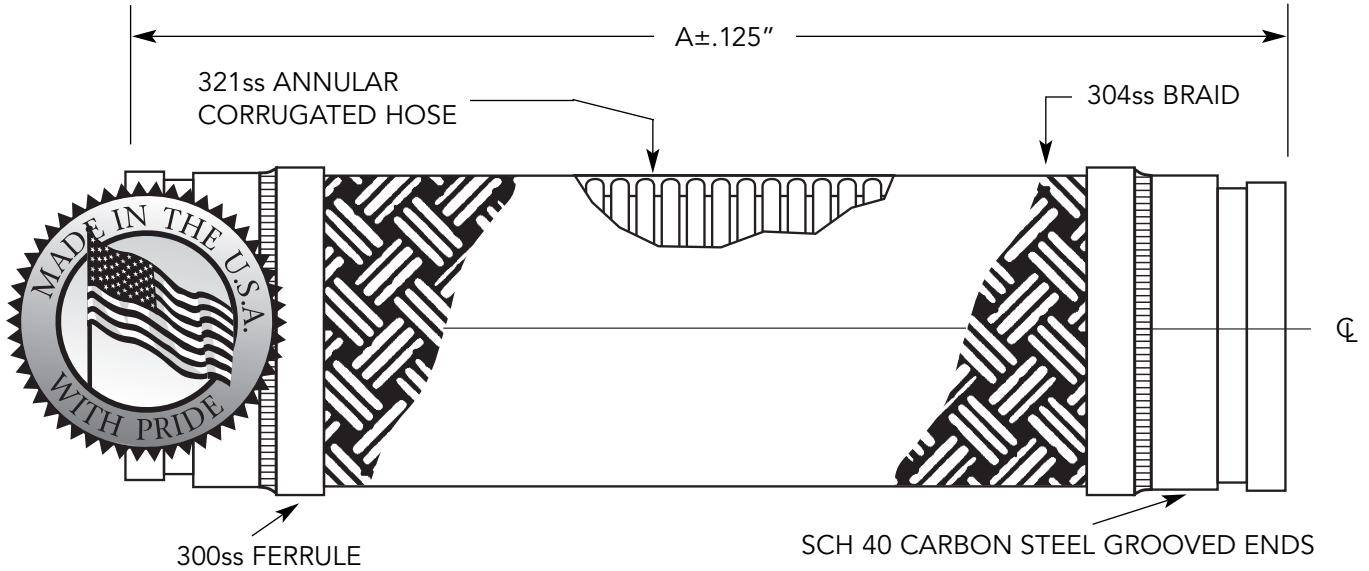

FOR TEMP ABOVE 70°F	
TEMP	FACTOR
70	1.00
200	.94
300	.88
400	.83
500	.78
600	.74

Qty.	I.D (in.)	A (in.)	Pressure (PSI) 70° F	Parallel Offset (in.)		Weight (lbs.)	Notes
				Permanent	Intermittent		
	2.00	12.00	500	1 1/4	3/8	3.90	
	2.50	12.00	400	1 1/4	3/8	4.50	
	3.00	12.00	285	3/4	1/4	6.10	
	4.00	14.00	250	1/2	1/4	9.30	
	5.00	16.00	200	7/8	3/8	11.80	
	6.00	16.00	220	5/8	1/4	16.80	
	8.00	16.00	200	1/2	1/4	23.50	
	10.00	20.00	200	5/8	1/4	44.10	
	12.00	20.00	160	1/2	1/4	51.50	

\*Working pressures shown for the hose and braid are based on an operating temperature of 70°F (21°C) with a 4:1 safety factor.

\*For safe working pressure above 70°F, multiply pressure shown at 70°F times correction factor of required temp.



This product is listed by IAPMO R&T under file #N-7208 for NSF/ANSI 61 and file 7207 for California Lead Plumbing Law and NSF/ANSI-372. Our listed products can be viewed on IAPMO R&T's Web listing at <http://pld.iapmo.org>



CSA standard B-51 certified. Inspected and tested by the Technical Standards and Safety Authority of Canada.



4560 Buckley Road  
 Liverpool, NY USA 13088-2509  
 315/437-1611 • Fax 315/437-1903  
[www.flexhose.com](http://www.flexhose.com) • 1.877.METAL EJ

PROJECT	
CUSTOMER	
ENGINEER	
REPRESENTATIVE	
DRAWING #	