

Pumpsaver® Braided Pump Connectors

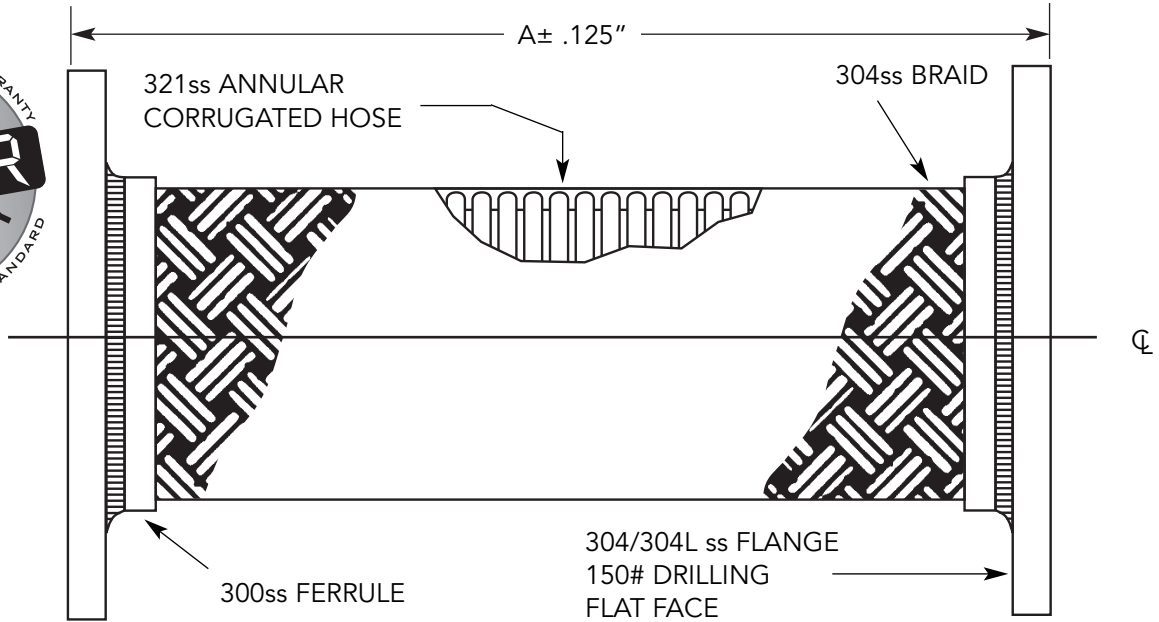

FOR TEMP ABOVE 70°F	
TEMP °F	FACTOR S.S.
70	1.00
200	.94
300	.88
400	.83
500	.78
600	.74

Qty.	I.D (in.)	A (in.)	Pressure (PSI) 70° F	Notes
	2.00		500	
	2.50		400	
	3.00		285	
	4.00		250	
	5.00		200	
	6.00		220	
	8.00		200	
	10.00		200	
	12.00		160	
	14.00		140	

*For safe working pressure above 70°F, multiply pressure shown at 70°F times correction factor of required temp.

*Working pressures shown for the hose and braid are based on an operating temperature of 70°F (21°C) with a 4:1 safety factor.



CSA standard B-51 certified. Inspected and tested by the Technical Standards and Safety Authority of Canada.



PROJECT	
CUSTOMER	
ENGINEER	
REPRESENTATIVE	
DRAWING #	



4560 Buckley Road
 Liverpool, NY USA 13088-2509
 315/437-1611 • Fax 315/437-1903
www.flexhose.com • 1.877.METAL EJ