

Pumpsaver® Braided Pump Connectors

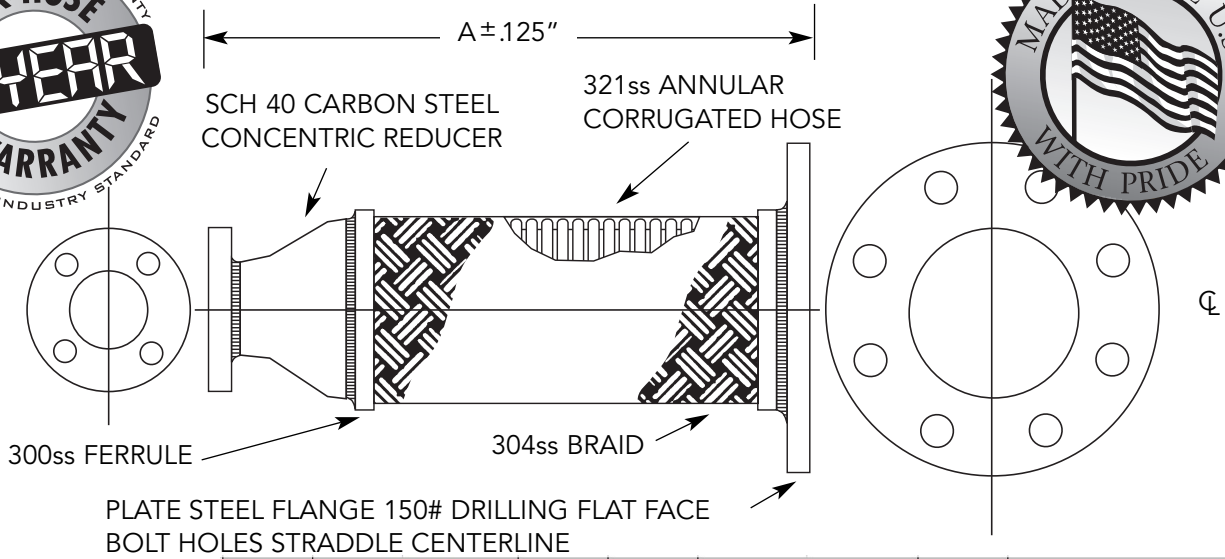

FOR TEMP ABOVE 70°F	
TEMP °F	FACTOR S.S.
70	1.00
200	.94
300	.88
400	.83
500	.78
600	.74

*For safe working pressure above 70°F, multiply pressure shown at 70°F times correction factor of required temp.



CSA standard B-51 certified. Inspected and tested by the Technical Standards and Safety Authority of Canada.

Qty.	I.D. (in.)		A (in.)	Pressure (PSI) 70° F	Parallel Offset (in.)		Weight (lbs.)	Notes
	Small Flange	Large Flange & Hose			Permanent	Intermittent		
	1.50	2.00	13.00	500	3/4	5/8	10.00	
	1.50	2.50	13.00	400	3/8	1/2	11.20	
	1.50	3.00	13.00	285	7/8	3/8	13.70	
	2.00	2.50	13.00	400	1/8	1/2	12.40	
	2.00	3.00	13.00	285	7/8	3/8	14.90	
	2.00	4.00	13.00	250	1/2	1/4	18.70	
	2.50	3.00	13.00	285	7/8	3/8	16.00	
	2.50	4.00	13.00	250	1/2	1/4	20.00	
	2.50	5.00	16.00	200	7/8	3/8	25.70	
	2.50	6.00	16.00	220	1/2	1/4	32.00	
	3.00	4.00	13.00	250	1/2	1/4	20.80	
	3.00	5.00	16.00	200	7/8	3/8	26.50	
	3.00	6.00	16.00	220	1/2	1/4	32.80	
	4.00	5.00	16.00	200	7/8	3/8	28.40	
	4.00	6.00	16.00	220	1/2	1/4	34.70	
	4.00	8.00	18.00	200	5/8	1/4	53.40	
	5.00	6.00	16.00	220	1/2	1/4	37.70	
	5.00	8.00	18.00	200	5/8	1/4	55.70	
	6.00	8.00	18.00	200	5/8	1/4	56.90	
	6.00	10.00	20.00	200	5/8	1/4	83.10	
	8.00	10.00	20.00	200	5/8	1/4	95.00	
	10.00	12.00	22.00	160	1/2	1/4	125.90	

*Working pressures shown for the hose and braid are based on an operating temperature of 70°F (21°C) with a 4:1 safety factor.

PROJECT	
CUSTOMER	
ENGINEER	
REPRESENTATIVE	
DRAWING #	



4560 Buckley Road
 Liverpool, NY USA 13088-2509
 Phone 315/437-1611 • Fax 315/437-1903
 www.flexhose.com • 1.877.TRI FLEX