

AssureFlex® Braided Pump Connectors for Fire Protection

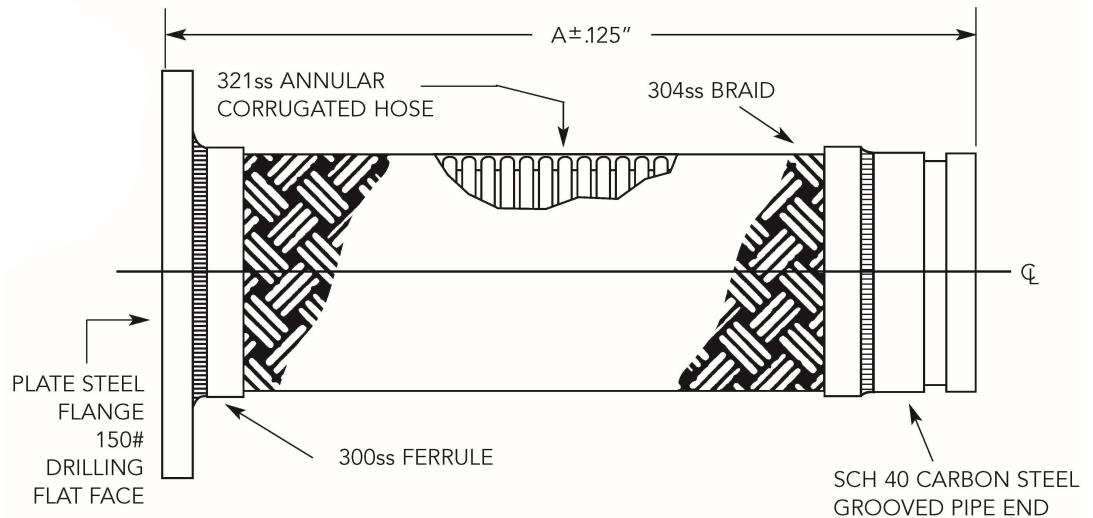

FOR TEMP ABOVE 70°F	
TEMP °F	FACTOR S.S.
70	1.00
200	.94
300	.88
400	.83
500	.78
600	.74

QTY	ID (in.)	A (in.)	Pressure (PSI) @70° F	Lateral Offset (in.)		Weight (lb.)	Notes
				Permanent (in.)	Intermittent (in.)		
	4.00	12.00	300	5/8	1/4	15	
	5.00	14.50	300	1/2	1/4	24	
	6.00	15.25	300	1/2	1/4	29	

*Working pressures shown for the hose and braid are based on an operating temperature of 70°F (21°C) with a 4:1 safety factor.

Provided with two braids.

*For safe working pressure above 70°F, multiply pressure shown at 70°F times correction factor of required temp.



CSA standard B-51 certified. Inspected and tested by the Technical Standards and Safety Authority of Canada.



PROJECT	
CUSTOMER	
ENGINEER	
REPRESENTATIVE	
DRAWING #	



4560 Buckley Road
 Liverpool, NY USA 13088-2509
 315/437-1611 • Fax 315/437-1903
 www.flexhose.com • 1.877.METAL EJ

