

# AssureFlex® Braided Pump Connectors for Fire Protection

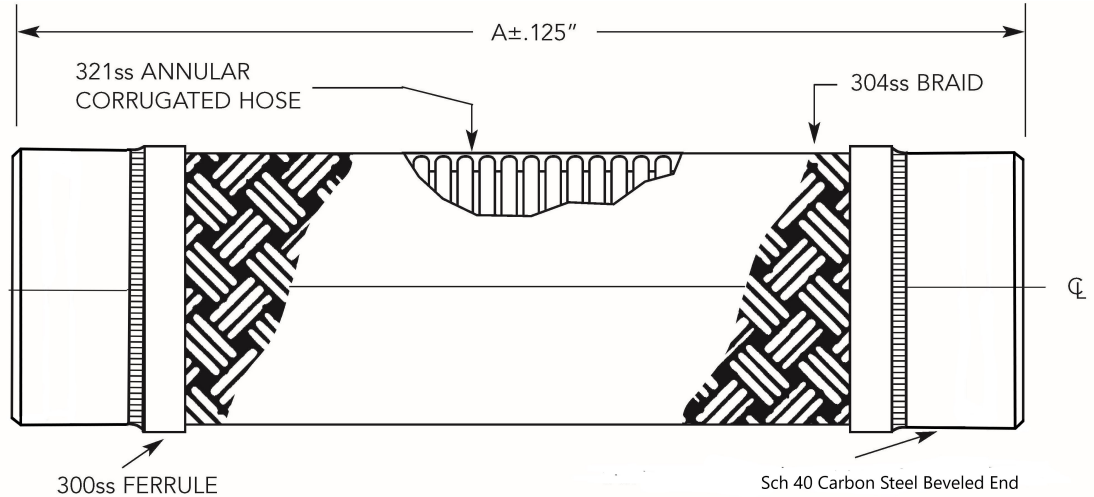

FOR TEMP ABOVE 70°F	
TEMP °F	FACTOR S.S.
70	1.00
200	.94
300	.88
400	.83
500	.78
600	.74

QTY	I.D. (in.)	A (in.)	Pressure (PSI) @ 70° F	Parrallel Offset Intermittent (in.)	Weight (lb.)	Notes
	4.00	16.00	300	1/8	10	
	5.00	17.00	300	1/8	17	
	6.00	18.00	300	1/8	21	

\*Working pressures shown for the hose and braid are based on an operating temperature of 70°F (21°C) with a 4:1 safety factor.  
8"-12" ID sizes provided with two braids.

\*For safe working pressure above 70°F, multiply pressure shown at 70°F times correction factor of required temp.



CSA standard B-51 certified. Inspected and tested by the Technical Standards and Safety Authority of Canada.



(Flexible Joint Fitting)

PROJECT	
CUSTOMER	
ENGINEER	
REPRESENTATIVE	
DRAWING #	



4560 Buckley Road  
Liverpool, NY USA 13088-2509  
315/437-1611 • Fax 315/437-1903  
www.flexhose.com • 1.877.METAL EJ

