

AssureFlex® Two-Leg U Style Seismic and Expansion Loop for Fire Protection

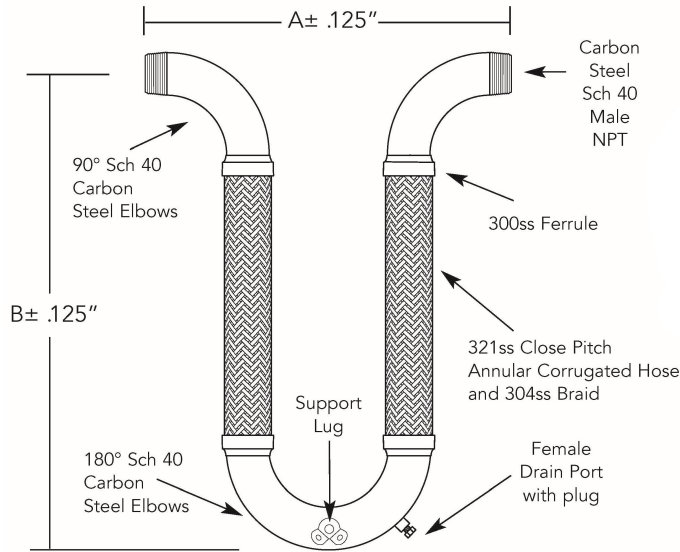

CSA standard B-51 certified.
Inspected and tested by the
Technical Standards and
Safety Authority of Canada.

QTY.	I.D. (in.)	Length (in.)		Pressure (PSI) @70° F	Drain Port (in.)	Weight (lb.)	Comments
		A (in.)	B (in.)				
	1.00	27.00	29.00	300	½	9.0	
	1.25	28.00	32.00	300	½	12.0	
	1.50	29.00	34.00	300	½	14.0	
	2.00	31.00	39.00	300	½	22.0	
	2.50	33.00	45.00	300	¾	38.0	
	3.00	35.00	48.00	300	¾	49.0	
	4.00	40.00	56.00	175	¾	79.0	

MOVEMENT CAPABILITY: +/- 16"

PROJECT	
CUSTOMER	
ENGINEER	
REPRESENTATIVE	
DRAWING #	



4560 Buckley Road
Liverpool, NY USA 13088-2509
315/437-1611 • Fax 315/437-1903
www.flexhose.com • 1.877.TRI FLEX