

# FLEXPRESS EXTERNALLY PRESSURIZED GUIDED EXPANSION JOINTS

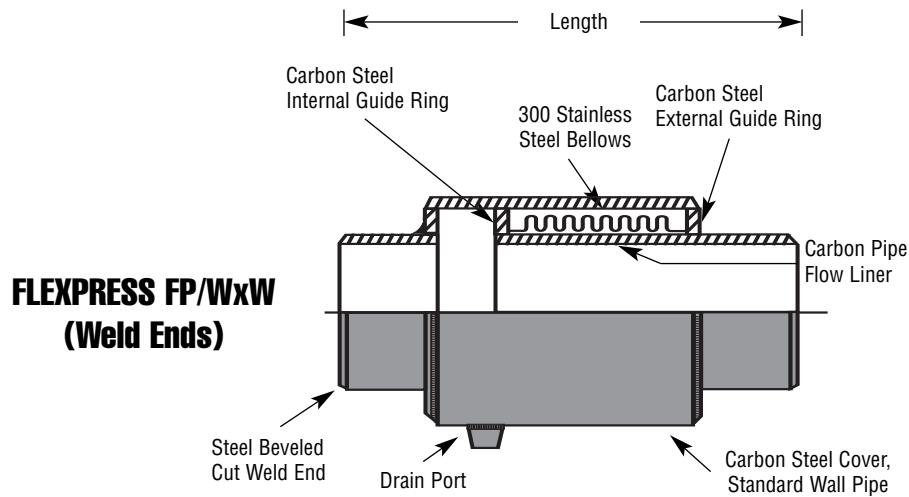

FP/150-WxW (Weld Ends)								
Design Pressure 110 PSIG		Test Pressure 165 PSIG		Max Temperature 750°F				
FP/300-WxW (Weld Ends)								
Design Pressure 225 PSIG		Test Pressure 335 PSIG		Max Temperature 750°F				
QTY	I.D. (In.)	Length (In.)		MOVEMENT CAPABILITY		Wt. (Lbs.)		NOTES
		FP/150-WxW	FP/300-WxW	Compression (In.)	Extension (In.)	FP/150-WxW	FP/300-WxW	
2.00	23.25	23.25	23.25	4.00	.75	33.00	35.00	
		32.00	32.00	6.00	1.12	46.00	48.00	
		39.25	39.25	8.00	1.50	55.00	58.00	
2.50	23.25	23.25	23.25	4.00	.75	35.00	36.00	
		32.00	32.00	6.00	1.12	50.00	52.00	
		39.25	39.25	8.00	1.50	60.00	63.00	
3.00	22.25	22.25	22.25	4.00	.75	46.00	47.00	
		28.50	28.50	6.00	1.12	57.00	59.00	
		37.25	37.25	8.00	1.50	74.00	78.00	
4.00	22.75	22.75	22.75	4.00	.75	72.00	74.00	
		29.50	29.50	6.00	1.12	89.00	94.00	
		38.50	38.50	8.00	1.50	116.00	124.00	
5.00	21.50	21.50	21.50	4.00	.75	95.00	97.00	
		27.50	27.50	6.00	1.12	116.00	120.00	
		33.75	33.75	8.00	1.50	138.00	143.00	
6.00	21.50	21.50	21.50	4.00	.75	102.00	106.00	
		27.50	27.50	6.00	1.12	125.00	130.00	
		33.75	33.75	8.00	1.50	149.00	155.00	
8.00	22.50	22.50	22.50	4.00	.75	161.00	168.00	
		29.00	29.00	6.00	1.12	198.00	209.00	
		35.75	35.75	8.00	1.50	236.00	250.00	
10.00	23.75	23.75	23.75	4.00	1.00	209.00	216.00	
		30.75	30.75	6.00	1.50	261.00	272.00	
		40.00	40.00	8.00	2.00	337.00	354.00	
12.00	24.50	24.50	25.00	4.00	1.00	257.00	285.00	
		32.00	32.50	6.00	1.50	324.00	355.00	
		41.75	42.25	8.00	2.00	419.00	457.00	

Burst to working pressure ratio is 4:1



CSA standard B-51 certified. Inspected and tested by the Technical Standards and Safety Authority of Canada.



PROJECT	
CUSTOMER	
ENGINEER	
REPRESENTATIVE	
DRAWING #	



4560 Buckley Road  
 Liverpool, NY USA 13088-2509  
 Phone 315/437-1611 • Fax 315/437-1903  
[www.flexhose.com](http://www.flexhose.com) • 1.877.TRI FLEX

Rev. 9/23-C

**FLEXPRESS-WELD ENDS**

**FP/WxW 2"-12" I.D.**