

Two-Leg V-Style Expansion Loops

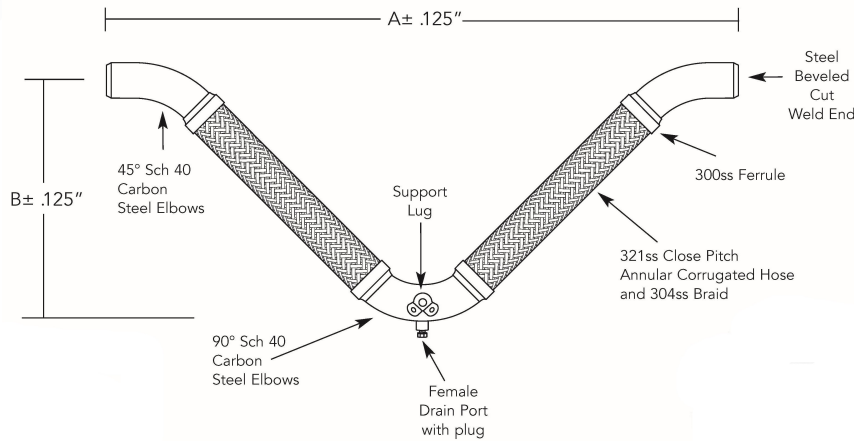

536 Listed

2-leg V style loop stainless steel 1/2"-4" for compressed and combustible gases at pressures not exceeding 175 PSI at ambient temperature. The term combustible gases, as used herein, means gases such as liquefied petroleum and natural gases. 33NB



Qty.	Pipe Size (in.)	Length (in.)		Pressure (PSI) 70°F	Drain Port (in.)	WT. (lbs.)	Comments
		A	B				
	1/2	30.00	12.25	175	1/4	3	
	3/4	32.13	13.13	175	1/4	4	
	1	35.88	14.25	175	1/2	6	
	1.25	40.50	16.50	175	1/2	8	
	1.5	43.13	17.00	175	1/2	9	
	2	46.63	18.38	175	1/2	14	
	2.5	52.25	21.00	175	3/4	23	
	3	58.13	23.13	175	3/4	30	
	4	65.50	26.25	175	3/4	50	

MOVEMENT CAPABILITY: +/- 4" SEISMIC; +/- 6" THERMAL

PROJECT	
CUSTOMER	
ENGINEER	
REPRESENTATIVE	
DRAWING #	



4560 Buckley Road
 Liverpool, NY USA 13088-2509
 315/437-1611 • Fax 315/437-1903
www.flexhose.com • 1.877.TRI FLEX