

# Two-Leg U-Style Expansion Loops

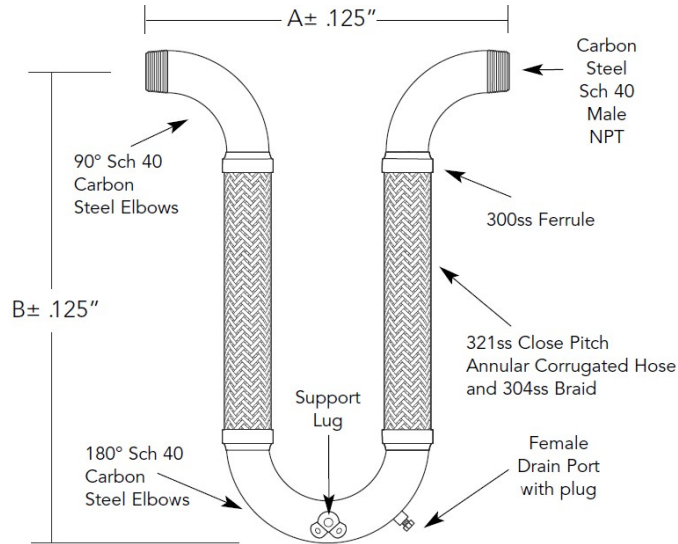

## 536 Listed

2-leg U style loop Stainless steel 1/2"-4" for compressed and combustible gases at pressures not exceeding 175 PSI at ambient temperature. The term combustible gases, as used herein, means gases such as liquefied petroleum gases and manufactured and natural gases.  
33NB

Qty.	Pipe Size (in.)	Length (in.)		Pressure (PSI)	Drain Port (in.)	WT. (lbs.)	Comments
		A	B	70°F			
	1/2	15.00	18.00	175	1/4	3.5	
	3/4	16.00	20.00	175	1/4	4	
	1	16.00	22.00	175	1/2	6.5	
	1.25	16.75	22.00	175	1/2	7	
	1.5	17.50	23.00	175	1/2	9	
	2	20.00	25.00	175	1/2	15	
	2.5	21.50	26.00	175	3/4	25	
	3	26.00	29.00	175	3/4	35	
	4	32.00	37.00	175	3/4	62	

MOVEMENT CAPABILITY: +/- 4"

PROJECT	
CUSTOMER	
ENGINEER	
REPRESENTATIVE	
DRAWING #	



4560 Buckley Road  
 Liverpool, NY USA 13088-2509  
 315/437-1611 • Fax 315/437-1903  
[www.flexhose.com](http://www.flexhose.com) • 1.877.TRI FLEX