

# Tri-Flex Loop® Expansion Loops & Seismic Connectors

## Movement Capabilities

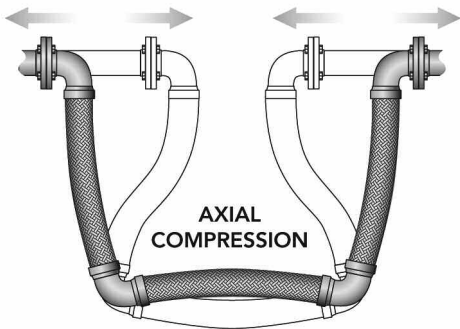

FRONT VIEW

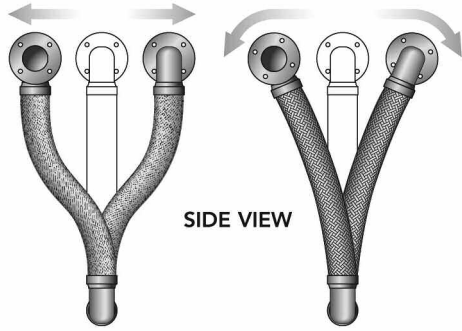

SIDE VIEW

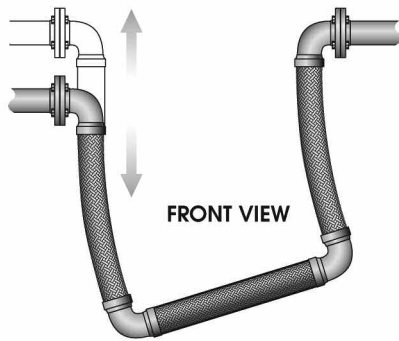

FRONT VIEW

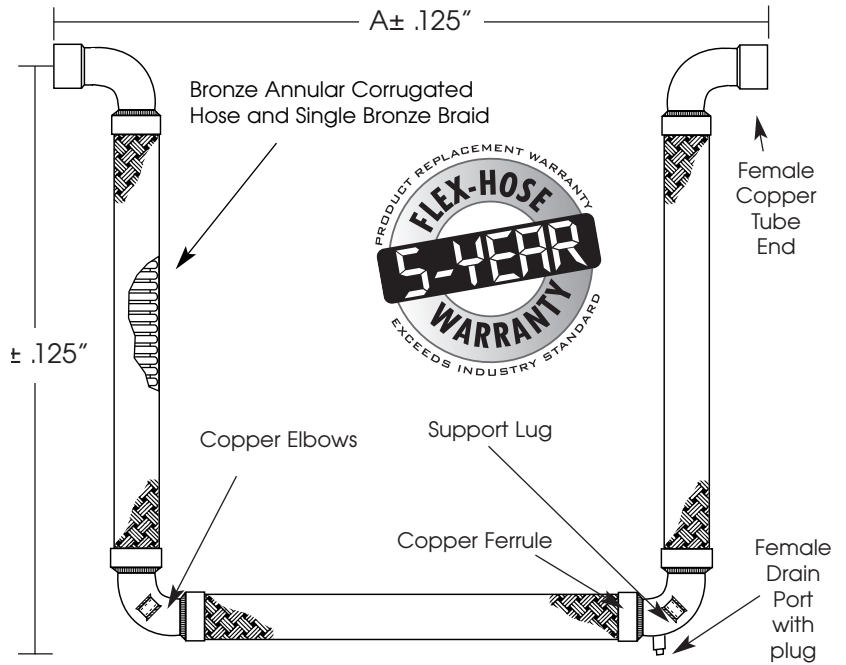

I.D. (IN)	LENGTH (IN)		PRESSURE (PSI)		MOVEMENT CAPABILITY					DRAIN PORT (IN)	WT (LBS)	NOTES
	A	B	70°F	200°F	COMPRESSION (IN)	EXTENSION (IN)	PARALLEL (IN)	ROTATION "X" AXIS (DEG)	NON-PARALLEL "Y" AXIS (IN)			
1/2	15.00	13.50	565	502	2	2	2	25°	1	1/4	3	
3/4	18.00	16.00	465	413	2	2	2	20°	1	1/4	5	
1.0	20.75	18.00	335	298	2	2	2	20°	1	1/2	6	
1.25	23.25	20.00	300	267	2	2	2	15°	1	1/2	10	
1.5	28.00	23.00	295	262	2	2	2	15°	1	1/2	13	
2.0	30.50	25.50	210	186	2	2	2	10°	1	1/2	19	
2.5	31.25	26.00	195	173	2	2	2	10°	1	3/4	27	
3.0	34.75	28.75	165	146	2	2	2	5°	1	3/4	33	

Working pressures shown for the hose and braid are based on an operating temperature of 70°F (21°C) with a 4:1 safety factor.



This product is listed by IAPMO R&T under file #N-7208 for NSF/ANSI 61 and file 7207 for California Lead Plumbing Law and NSF/ANSI-372. Our listed products can be viewed on IAPMO R&T's Web listing at <http://pld.iapmo.org>. This BSW copper product has been evaluated for use in drinking water systems pH 6.5 and above. Drinking water supplies that are less than pH 6.5 may require corrosion control to limit leaching of copper into the drinking water.



CSA standard B-51 certified. Inspected and tested by the Technical Standards and Safety Authority of Canada.

PROJECT	
CUSTOMER	
ENGINEER	
REPRESENTATIVE	
DRAWING #	



4560 Buckley Road • Liverpool, NY USA 13088-2509  
 315/437-1611 • Fax 315/437-1903  
[www.flexhose.com](http://www.flexhose.com) • 1.877.TRI FLEX